

20700 Series Double Gate Valves(One Piece Body no Welded)

DECON Characteristics

- Basic design:ASME B16.34/API602
Butt welding ends : ASME B16.25
Flange ends:ASME B16.5
Test standard:API598
- One piece forged body
- PSB design&Zero welded spot
- Standard graphite stem packing for temperature services up to 1200°F
- Standard tip material Stellite and high pressure up to 6000psig.
- Process size and end connection: DN40-DN200
- Material: A105, 316SS, 321SS, 347SS etc.
- Contact the authorized representative or DECON for any request.

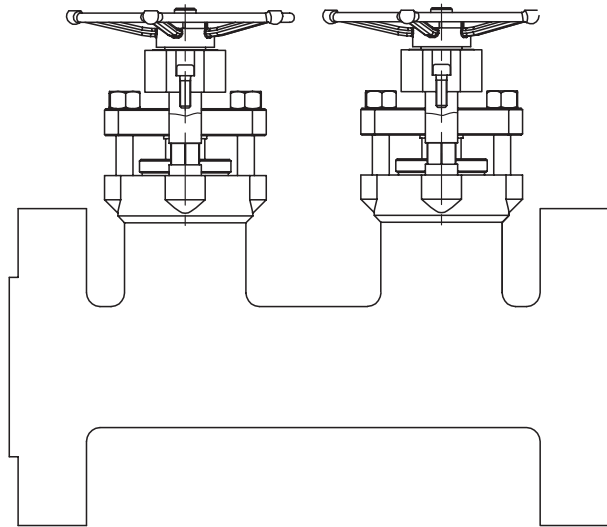

DBB Gate Valve PSB Main Material			
Ref.	Description	Body Mat:A105	Body Mat:F321
1	Body	A105	F321
2	Seat	A105+STL	F321+STL
3	Disc	A105+STL	F321+STL
4	Stem	17-4PH	A182 F XM-19
5	Bonnet	A105+STL	A182 F321+STL
6	Packing	Graphite	Graphite
7	Handwheel	ASTM A536	ASTM A536
8	Bolt/Nut	ASTM A193 B16 CL2/ASTM A194 7	ASTM A193 B16 CL2/ASTM A194 7